

We promise, We deliver

NOBLELIFT NORTH AMERICA CORP

Add: 2461 S Wolf Road
Des Plaines, IL 60018
Tel: 001-847-595-7100
Fax: 001-847-595-7200
Email: sales@nobeliftna.com
Http: www.nobeliftna.com

NOBLELIFT EUROPE GMBH

Add: Borsigstrasse
9-93082 Barbing Germany
Tel: +49 9401 607930
Fax: +49 9401 6079329
Email: mail@nobelifteurope.com
Http: www.nobelifteurope.com

NOBLELIFT RUSSIA

ООО «Ноблелифт Рус»
194292, Санкт-Петербург
Домостроительная ул. 4А офис 301
Тел.: +7-800-700-28-97
Email: sales@nobelift.com.ru
Http: www.nobelift.com.ru



NOBLELIFT CHINA

Add: 528 Changzhou Road, Taihu Sub-district,
Changxing, Zhejiang 313100 China
Tel: 86-572-6210817 6210311
Fax: 86-572-6210777 6128612
Email: info@nobelift.com
Http: www.nobelift.com www.nobelift.cn



Official website



Our Wechat

FE4P30Q-Li/FE4P35Q-Li

Four wheel Li-iron Electric Forklift



NEW / *Nobelift Products*
ARRIVAL

NOBLELIFT INTELLIGENT EQUIPMENT CO., LTD

www.nobelift.com

FE4P30Q-Li/FE4P35Q-Li

- The FE4P30Q-Li/35Q-Li is a cost-effective electric forklift with combination of the traditional Internal Combustion forklift and lithium-iron powered electric forklift, it has the characteristics of large driving space and comfortable operation. The standard configuration is lithium iron phosphate (LFP) battery with efficient fast charging. Optional different battery capacities: the standard configuration is 80V200Ah, optional 80V300Ah and 400Ah.
- Standard full AC control system and optional fleet management system. Standard REMA/Anderson connection for charging, optional automotive type intelligent plug-in high frequency charging technology.
- The truck adopt similar design of the Internal Combustion forklift with spacious operation space and comfort. The mast system, front and rear axles as well as the the durability of chassis is similar to traditional Internal Combustion forklift. The truck combined the durability of Internal Combustion forklift with layout advantage of Li-iron electric forklift, so that the truck's weight is light and and gravity center is optimized, therefore the overall energy consumption is effectively improved.

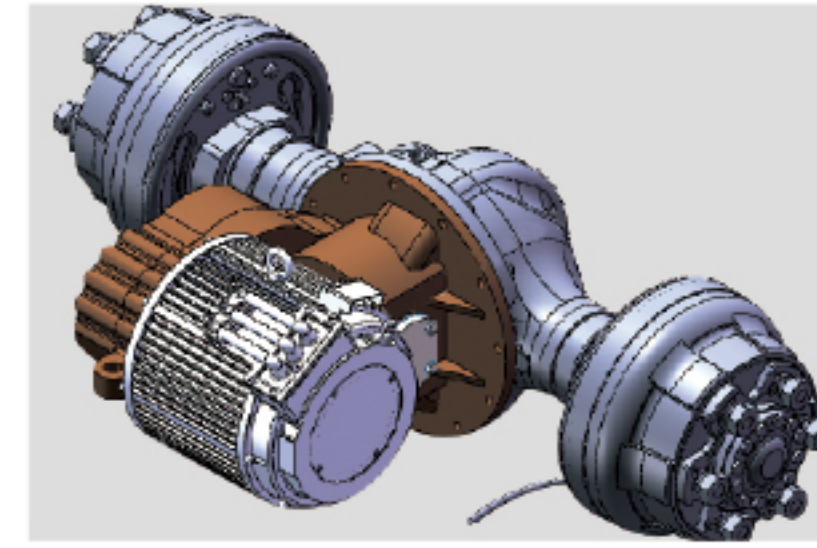

Drive system uses a horizontal fan-shaped drive axle arranged in parallel with a large transmission ratio. The battery is located at the bottom of chassis, the truck has good stability. Drive motor uses AC maintenance-free motor. Long wheelbase(1700mm)design, better stability.

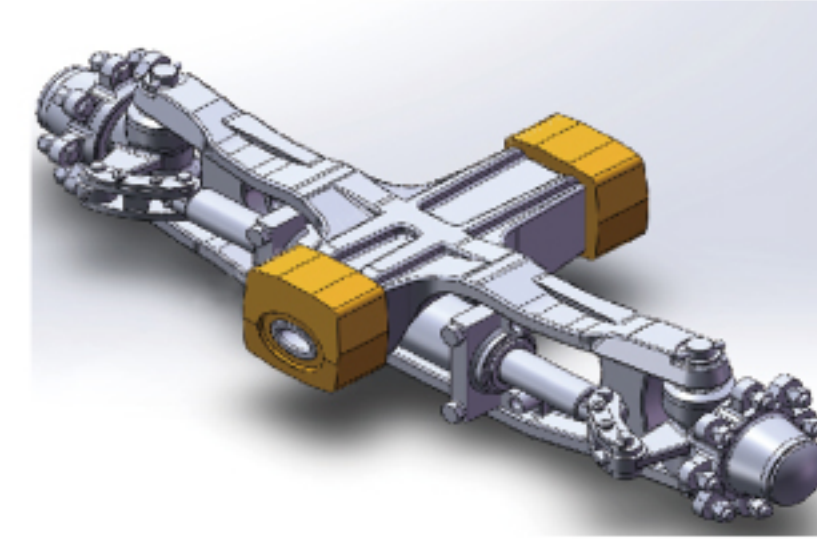

Integrally forged Integrated steering axle, with shock mitigation system with excellent driving comfort and prolongs the service life.

Ergonomically designed LED display with large screen and great visibility for easy control and operation with all around truck status information.



U design of steering wheel, front-located multi-way valve operating device makes the operation effortless and comfortable.



The truck adopts long tiller ratchet parking brake design for easy operation.



The simple and convenient removable side panel design allows the battery can be side extracted as standard feature for efficient and easy battery replacement. Electronic controller: located on side bottom part for good heat dissipation ,easy maintenance and installation. Large front and rear tire design, works both for outdoor off-road and indoor road surface with good driving comfort.



Simplified structure design by eliminating unnecessary decorative structures with same strength , make the truck look more attractive and tough.

Q Series Forklift Lithium battery option (LFP)			
Model	Standard	Optional	
FE4P30Q-Li	200Ah	300Ah	400Ah
FE4P35Q-Li	200Ah	300Ah	400Ah



All lithium-iron batteries are equipped built-in battery management system(BMS) that manages all important data during charging and discharging. The management of the battery by BMS can ensure the safety of the battery throughout its life cycle. **Lithium-iron batteries have been certified for safe transportation(by air and sea)and operating standards.** BMS communicates with the truck management system through CAN. CAN protocol CAN monitor the battery and diagnose and repair the battery through specific software.



Battery replacement: side extraction, quick and convenient replacement, easy maintenance. Fast charging with battery fully charged in 2-3 hours. The intelligent high frequency charger with automobile charging technology has a working efficiency of more than 95%, which is much higher than the 80% working efficiency of traditional low frequency charger.



Optional: automotive type intelligent plug-in charging gun with high frequency charging technology. **Note: press the "stop" button of the charger before pulling the gun.**



Standard: REMA/Anderson plugin.



Wide view through the optimized mast and hydraulic design, the forks with intelligent buffer, protect the ground and goods from damage from hitting the ground.



Combination switch as automotive, the seat can be adjusted back and forth so that the operator can choose the ideal driving position.

Mast Table FE4P30Q-Li						
Designation	Lift height h3 (mm)	Free Lift h2 (mm)	Closed mast height h1 (mm)	Extended mast height h4 (mm)	Tilt forward/ backward $\alpha/\beta(^{\circ})$	Capacity table(kg) C=500mm without sideshift, single pneumatic tyres FE4P30Q-Li
Two-stage ZT	2000	135	1570	3114	6/10	3000
	2500	135	1820	3614	6/10	3000
	3000	135	2070	4114	6/10	3000
	3300	135	2220	4414	6/10	3000
	3500	135	2320	4614	6/10	3000
	3600	135	2370	4714	6/10	3000
	3700	135	2420	4814	6/10	2950
	4000	135	2620	5114	6/6	2850
	4300	135	2770	5414	6/6	2700
	4500	135	2870	5614	6/6	2500
5000	135	3120	6114	6/6	2100	
Two-stage ZZ	2000	563	1545	2971	6/10	3000
	2500	813	1795	3471	6/10	3000
	3000	1063	2045	3971	6/10	3000
	3300	1213	2195	4271	6/10	3000
	3500	1313	2295	4471	6/10	3000
	3600	1363	2345	4571	6/10	3000
	3700	1413	2395	4671	6/6	3000
	4000	1613	2595	4971	6/6	2850
Three-stage DZ	4000	988	1970	4981	6/6	2750
	4300	1113	2095	5331	6/6	2600
	4500	1163	2145	5479	6/6	2400
	4800	1263	2245	5779	6/6	2200
	5000	1406	2388	5979	6/6	2000
	5500	1640	2622	6479	3/6	1500
	6000	1873	2855	6979	3/6	1200
	6500	2107	3088	7479	3/3	800

Free lift height (no load-backrest) +425mm

Mast Table FE4P35Q-Li						
Designation	Lift height h3 (mm)	Free Lift h2 (mm)	Closed mast height h1 (mm)	Extended mast height h4 (mm)	Tilt forward/ backward $\alpha/\beta(^{\circ})$	Capacity table(kg) C=500mm without sideshift, single pneumatic tyre FE4P35Q-Li
Two-stage ZT	2000	140	1680	2786	6/10	3500
	2500	140	1930	3286	6/10	3500
	3000	140	2180	3786	6/10	3500
	3300	140	2330	4086	6/10	3500
	3500	140	2430	4286	6/10	3500
	3600	140	2480	4386	6/10	3500
	3700	140	2530	4486	6/10	3250
	4000	140	2730	4786	6/6	3000
	4300	140	2880	5086	6/6	2800
	4500	140	2980	5286	6/6	2600
5000	140	3230	5786	6/6	2200	
Two-stage ZZ	2000	491	1570	2971	6/10	3500
	2500	741	1820	3471	6/10	3500
	3000	991	2070	3971	6/10	3500
	3300	1141	2220	4271	6/10	3500
	3500	1241	2320	4471	6/10	3500
	3600	1291	2370	4571	6/10	3500
	3700	1341	2420	4671	6/6	3500
	4000	1541	2620	4971	6/6	3200
Three-stage DZ	4000	916	1970	4981	6/6	3200
	4300	1041	2095	5331	6/6	3000
	4500	1091	2145	5479	6/6	3000
	4800	1191	2245	5779	6/6	2500
	5000	1334	2388	5979	6/6	2400
	5500	1568	2622	6479	3/6	1750
	6000	1801	2855	6979	3/6	1250
	6500	2034	3088	7479	3/3	900

Free lift height (no load-backrest) +460mm

FE4P30Q-Li/FE4P35Q-Li Battery Balance Weight Type Forklift				
Identification				
1.1	Manufacture(abbreviation)		Noblelift	
1.2	Manufacturer's type designation		FE4P30Q-Li	FE4P35Q-Li
1.3	Drive:electric(battery or mains),diesel,petrol gas,manual		electric	
1.4	Type of operation(hand,pedestrian,standing,seated,order-picker)		seated	
1.5	Load capacity/rated load	Q(kg)	3000	3500
1.6	Load centre distance	C (mm)	500	
1.8	Load distance,centre of drive axle to fork	x (mm)	478	483
1.9	wheelbase	y (mm)	1700	
Weights				
2.1	Service weight incl. battery(see line 6.5)	kg	4150	4620
2.2	Axle loading ,laden front/rear	kg	6600/550	7470/650
2.3	Axle loading,unladen front/rear	kg	1800/2350	1920/2700
Wheels, Chassis				
3.1	Type:solid rubber,superelastic,pneumatic,polyurethane		pneumatic	superelastic
3.2	Tyres size,front		28×9-15-14PR	
3.3	Tyres size,rear		6.50-10-10PR	
3.5	Wheels,number front/rear(×=driven wheels)		2×/2	
3.6	Track width,front	b10 (mm)	1004	
3.7	Track width,rear	b11 (mm)	982	
Basic Dimensions				
4.1	Mast/fork carriage tilt forward/backward	$\alpha/\beta(^{\circ})$	6/10	
4.2	lowered mast height	h1 (mm)	2070	2185
4.3	Free lift	h2 (mm)	135	140
4.4	Lift height	h3 (mm)	3000	
4.5	Extended mast height	h4 (mm)	4115	
4.7	Overhead load guardheight	h6 (mm)	2150	
4.8	Seat height/standing height	h7 (mm)	1130	
4.12	Coupling height	h10 (mm)	580	
4.19	Overall length	l1 (mm)	3673	
4.20	Length to face of forks	l2 (mm)	2603	
4.21	Overall width	b1 (mm)	1226	
4.22	Fork dimensions	s/e1 (mm)	45/125/1070	50/125/1070
4.24	Fork carriage width	b3 (mm)	1100	
4.31	Ground clearance ,laden,under mast	m1 (mm)	135	
4.32	Ground clearance,centre of wheelbase	m2 (mm)	150	
4.33	Aisle width for pallets 1000×1200 crossways	Ast (mm)	4037	4042
4.34	Aisle width for pallets 800×1200 lengthways	Ast (mm)	4237	4242
4.35	Turning radius	Wa (mm)	2350	
Performance Data				
5.1	Travel speed,laden/unladen	km/h	11/12	10/11
5.2	Lift speed,laden/unladen	m/s	0.26/0.34	0.25/0.33
5.3	lowering speed,laden/unladen	m/s	< 0.6	
5.5	Drawbar pull ,laden/unladen S2 60 min	N	3500/2500	3800/2800
5.7	Max.Gradient performance,laden/unladen S2 5 min	%	15/15	13/15
5.10	Service brake		Hydraulic	
E-Motor				
6.1	Drive motor rating S2 60 min	kW	11	
6.2	Lift motor rating at S3 15%	kW	12	
6.3	Battery standard		Lion	
6.4	Battery voltage,nominal capacity K5	V/Ah	80/200 80/300/400 (option)	
6.5	Battery weight	kg	200	
Other Details				
8.1	Type of drive control		AC	
8.2	Operating pressure for attachments	Mpa	17.5	
8.3	Oil volume for attachments	l/min	36	
8.4	Sound level at driver's ear according to EN 12 053	dB(A)	74	75