

# SPARE PARTS LIST

## Electric Pallet Truck PTE20N

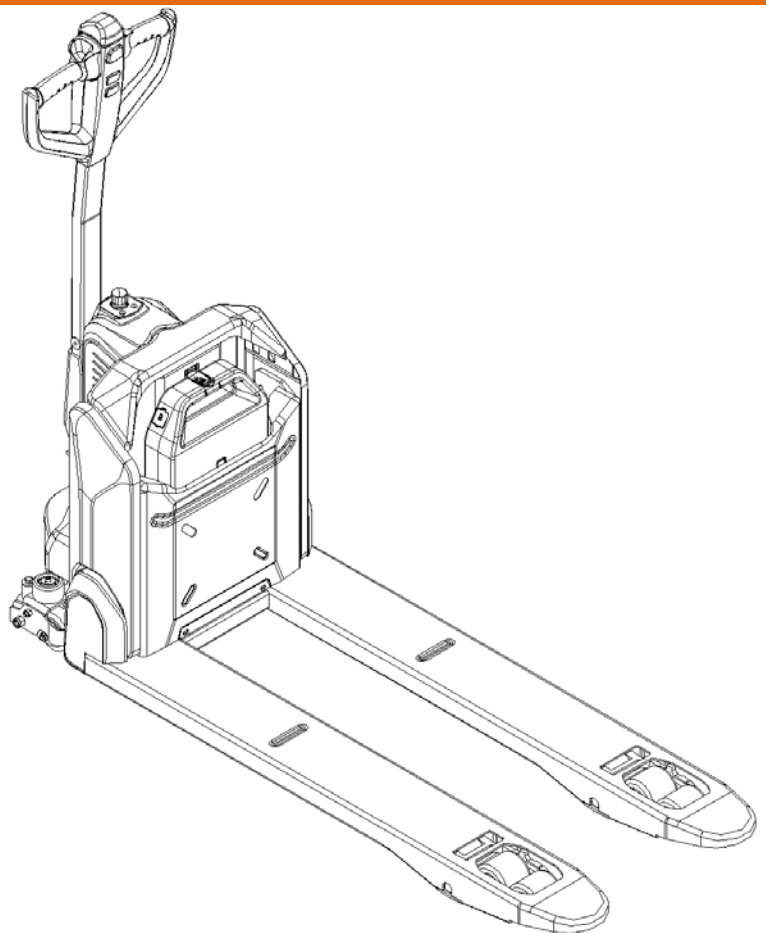

Version 02/2019

From truck identification number:

PTE20N -BPT-001-CHN

# Catalogue

Fig. 1 Chassis (540x800/915/1000/1150/1220).....	3
Fig. 2 Chassis (685x800/915/1000/1150/1220).....	5
Fig. 3 Load roller components .....	7
Fig. 4 Driving unit.....	9
Fig. 5 Driving wheel components .....	11
Fig. 6 Cylinder.....	12
Fig. 7 Power unit.....	14
Fig. 8 Hydraulic components .....	16
Fig. 9 Steering wheel components (with side rollers).....	17
Fig. 10 Tiller head .....	18
Fig. 11 Tiller arm components.....	20
Fig. 12 Load backrest components .....	22
Fig. 13 Truck components .....	23
Fig. 14 Power supply assembly.....	25
Fig. 15 Controller components .....	26
Fig. 16 Charger .....	27
Fig. 17 Wiring harness.....	28
Fig. 18 Sticker (EU).....	29
Fig. 19 Sticker (US).....	30
Easy worn parts list.....	31

**Fig. 1 Chassis (540x800/915/1000/1150/1220)**

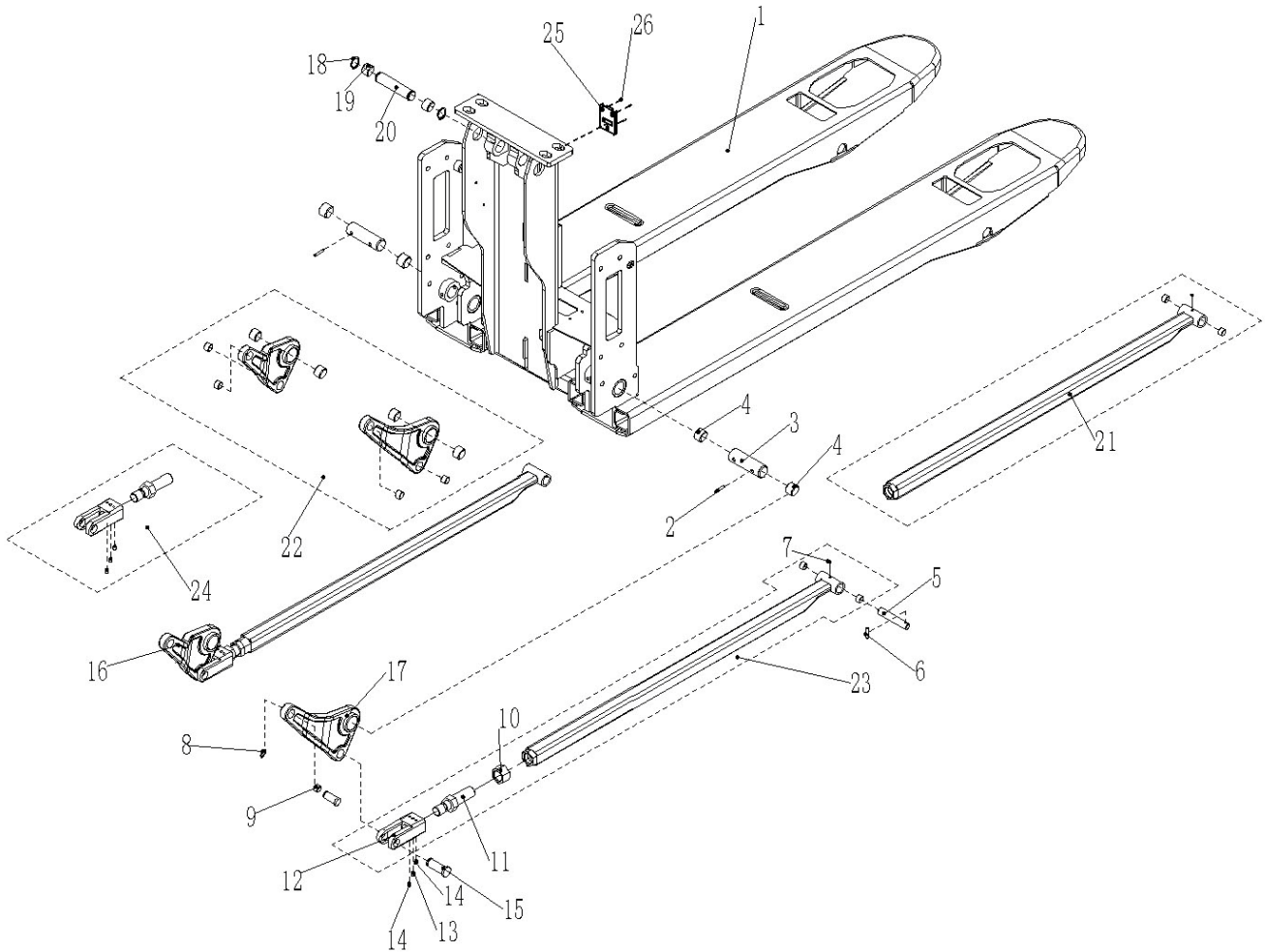
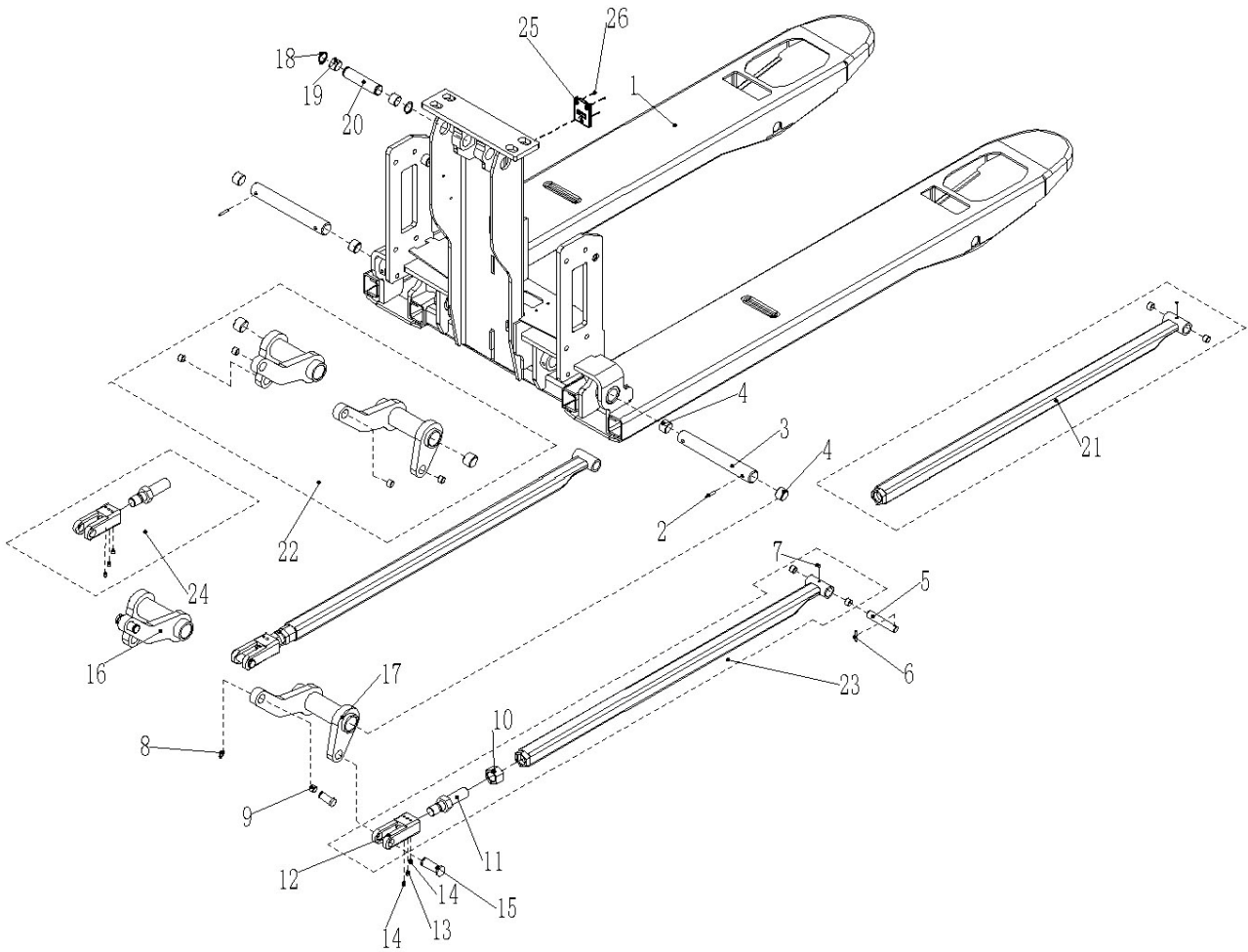

**Fig. 1 Chassis (540x800/915/1000/1150/1220)**

No.	Art No.	Description	Qty.	Note
1	508538510013	Chassis welding	1	540x800
	508538510012	Chassis welding	1	540x915
	508538510010	Chassis welding	1	540x1000
	508538510005	Chassis welding	1	540x1150
	508538510011	Chassis welding	1	540x1220

2	910600400041	Cylindrical pin	2	6x40
3	508538520019	Axle	2	Φ 25x82
4	940500100033	Bushing	4	25x29x12
5	502338520030	Push rod axle	2	Φ 16x82
6	910600400024	Cylindrical pin	2	5x28
7	911200100001	Grease nipple	2	6
8	910401300007	Circlip	4	16
9	940500100006	Bushing	8	16x18x15
10	910300400008	Nut	2	M20x1.5
11	508038520029	Bolt	2	
12	508038520028	Push rod fork	2	
13	910201000005	Screw	2	M6x8
14	910600400015	Cylindrical pin	4	4x30
15	508038520041	Short axle	4	Φ 16x44
16	508538510003	Rock arm welding	1	Left
17	508538510004	Rock arm welding	1	Right
18	910401300011	Circlip	2	20
19	940500100078	Bushing	2	20x23x22
20	508538520016	Short axle	1	Φ 20x92
21	508098510037	Push rod components	2	800
	508098510005	Push rod components	2	915
	508098510040	Push rod components	2	1000
	508098510000	Push rod components	2	1150
	508098510041	Push rod components	2	1220
22	508598510000	Rock arm components	1	540
23	508098510038	Push rod kits	2	800
	508098510006	Push rod kits	2	915
	508098510043	Push rod kits	2	1000
	508098510002	Push rod kits	2	1150
	508098510044	Push rod kits	2	1220
24	508598510014	Push rod fork components	2	
25	508038520109	Lock catch	1	
26	910200500034	Screw	3	M4x8

**Fig. 2 Chassis (685x800/915/1000/1150/1220)**

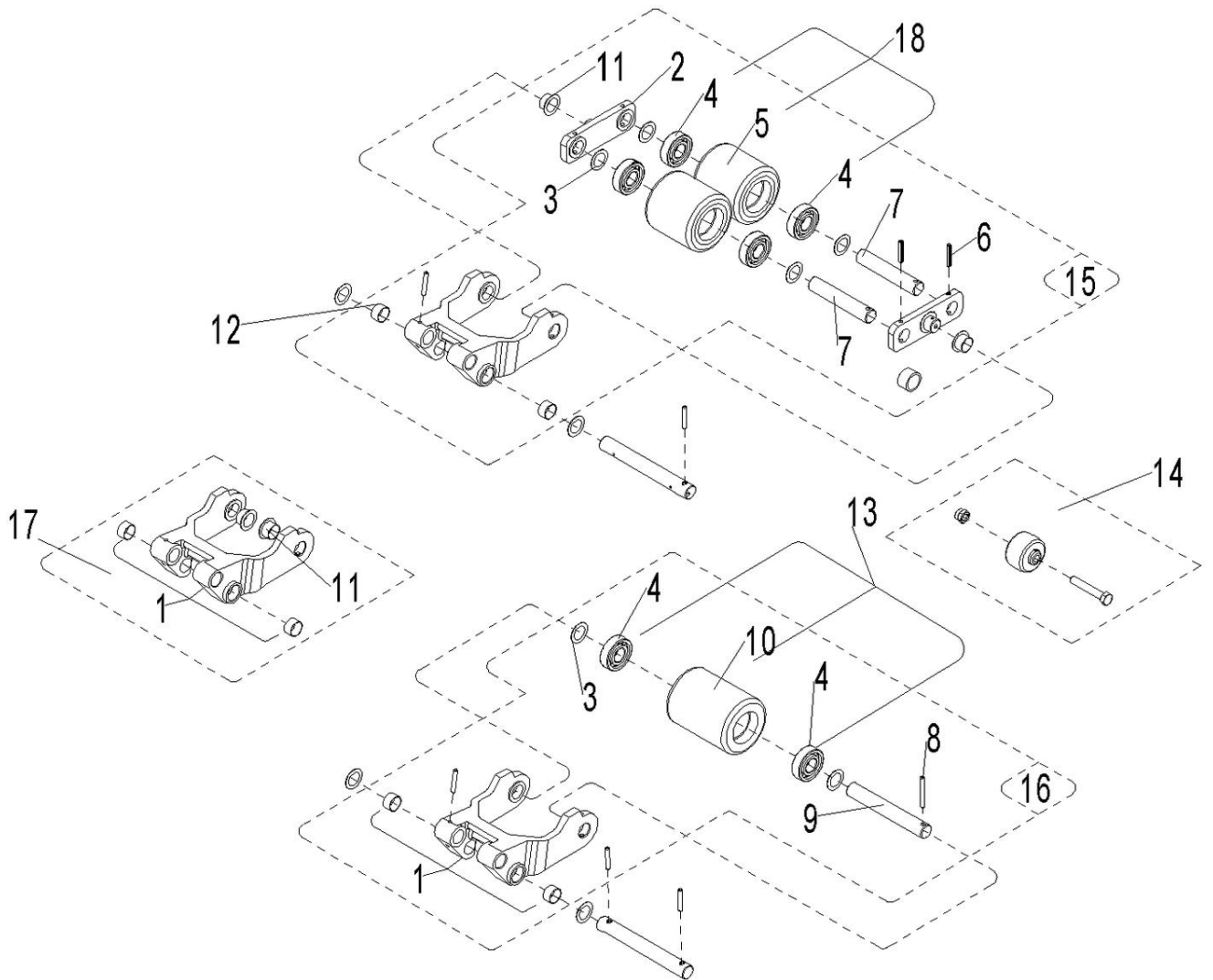

**Fig. 2 Chassis (685x800/915/1000/1150/1220)**

No.	Art No.	Description	Qty.	Note
1	508538510009	Chassis welding	1	540x800
	508538510008	Chassis welding	1	540x915
	508538510006	Chassis welding	1	540x1000
	508538510000	Chassis welding	1	540x1150
	508538510007	Chassis welding	1	540x1220
2	910600400041	Cylindrical pin	2	6x40

3	508538520015	Axle	2	Φ 25x181
4	940500100032	Bushing	4	25x29x25
5	502338520030	Push rod axle	2	Φ 16x82
6	910600400024	Cylindrical pin	2	5x28
7	911200100001	Grease nipple	2	6
8	910401300007	Circlip	4	16
9	940500100006	Bushing	8	16x18x15
10	910300400008	Nut	2	M20x1.5
11	508038520029	Bolt	2	
12	508038520028	Push rod fork	2	
13	910201000005	Screw	2	M6x8
14	910600400015	Cylindrical pin	4	4x30
15	508038520041	Short axle	4	Φ 16x44
16	508538510001	Rock arm welding	1	Left
17	508538510002	Rock arm welding	1	Right
18	910401300011	Circlip	2	20
19	940500100078	Bushing	2	20x23x22
20	508538520016	Short axle	1	Φ 20x92
21	508098510037	Push rod components	2	800
	508098510005	Push rod components	2	915
	508098510040	Push rod components	2	1000
	508098510000	Push rod components	2	1150
	508098510041	Push rod components	2	1220
22	508598510001	Rock arm components	1	685
23	508098510038	Push rod kits	2	800
	508098510006	Push rod kits	2	915
	508098510043	Push rod kits	2	1000
	508098510002	Push rod kits	2	1150
	508098510044	Push rod kits	2	1220
24	508598510014	Push rod fork components	2	
25	508038520109	Lock catch	1	
26	910200500034	Screw	3	M4x8

Fig. 3 Load roller components

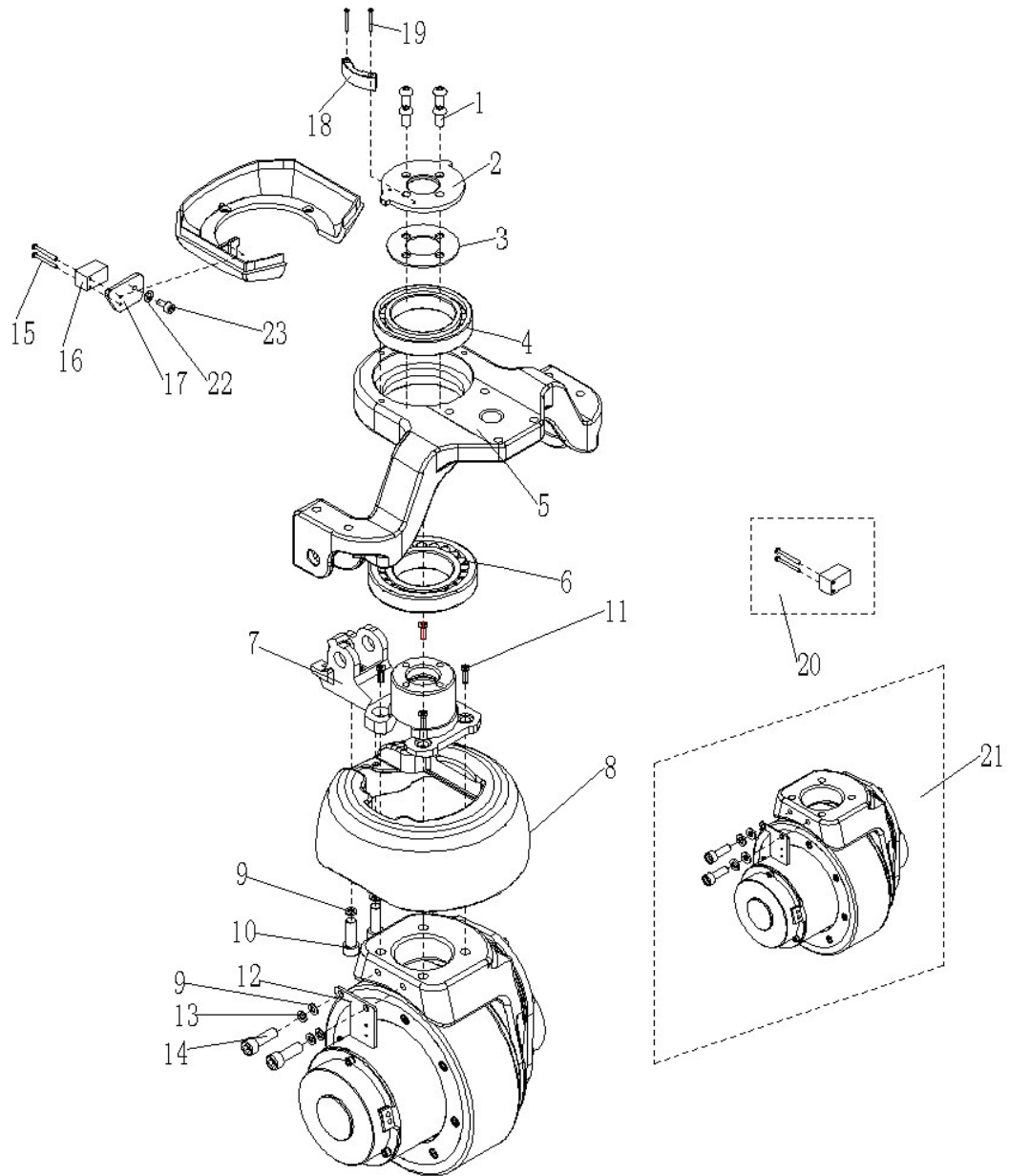

**Fig. 3 Load Roller Components**

No.	Art No.	Description	Qty.	Note
1	502398510018	Frame of roller components (75mm Single)	2	Low profile
2	502317020000	Linking plate	4	Tandem
3	940600500013	Washer $\Phi$ 25x $\Phi$ 20.5x1	8/4(Tandem/single)	
4	910700200019	Bearing GB276-6204-2RS	8/4(Tandem/single)	
5	940300300005	Roller $\Phi$ 80x70(Steel core PU)	4(Tandem)	
6	910600400027	Elastic cylindrical pin GB879.1-5x35	8(Tandem)	
7	502317020001	Wheel axle $\Phi$ 20x94	4(Tandem)	
8	910600400027	Elastic cylindrical pin GB879.1-5x35	8(Tandem)	
9	301017020001	Roller axle $\Phi$ 20x122	2(Single)	
10	940300300023	Roller $\Phi$ 80x93(Steel core PU)	2(Single)	
11	940500200003	Bushing (With shoulder) $\Phi$ 18x $\Phi$ 20x12-SF-1	4(Tandem)	
12	940500100012	Bushing $\Phi$ 20x $\Phi$ 22x12-SF-1	4	
13	502398510014	Wheel set kits (single)	2	
14	502398510003	Entry roller kits	2	
15	502398510020	Wheel kits (Tandem)	2	
16	502398510017	Wheel kits (single)	2	
17	502398510019	Frame of roller components (75mm tandem)	2	Low profile
18	502398510002	Wheel set kits (Tandem)	2	



**Fig. 4 Driving unit**

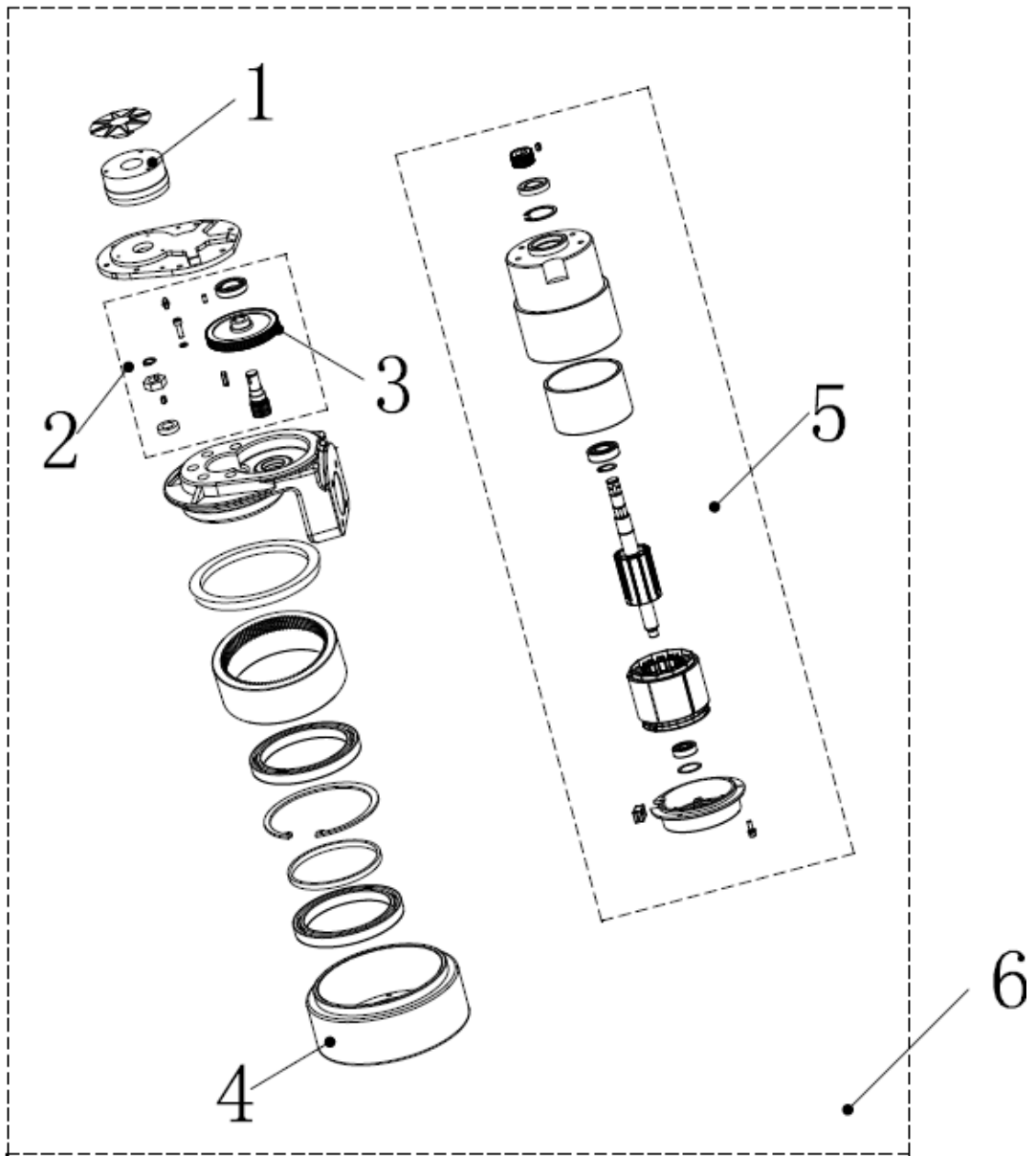

**Fig. 4 Driving Unit**

No.	Art No.	Description	Qty.	Note
1	910200300024	Screw	4	M8x16
2	508513520002	Bearing cap	1	

3	508013520004	Washer	1	
4	910700200058	Bearing	1	6013
5	508513520001	Driving wheel seat	1	
6	910700600044	Bearing	1	32913
7	508513520000	Linking flange	1	
8	508013520101	Round cover	1	
9	910400100005	Flat washer	4	6
10	910200200032	Screw	2	M6x10
11	910200200076	Screw	4	M10x25
12	508513520003	Driving plug plate	1	
13	910400500005	Spring washer	2	6
14	910200200033	Screw	2	M6x12
15	910200200007	Screw M3x25	2	With speed reduction on curve
16	920200400025	Proximity switch AZ17M05PB30	1	With speed reduction on curve
17	508533020001	Mounting plate	1	With speed reduction on curve
18	508533020000	Sensor block	1	With speed reduction on curve
19	910200500015	Screw M3x20	2	With speed reduction on curve
20	508598510002	Proximity switch components	1	With speed reduction on curve
21	508598510003	Driving components	1	
22	910400100003	Flat washer	1	4
23	910200300005	Screw	1	M4x8

**Fig. 5 Driving wheel components**



**Fig. 5 Driving Wheel Components**

No.	Art No.	Description	Qty.	Note
1	508098520002	Brake	1	
2	508098510015	Gear box components	1	
3	508098520004	Big gear ring	1	
4	508098520003	Rubber wheel	1	
5	508598510012	Motor components	1	
6	940900100011	Driving assembly	1	

**Fig. 6 Cylinder**

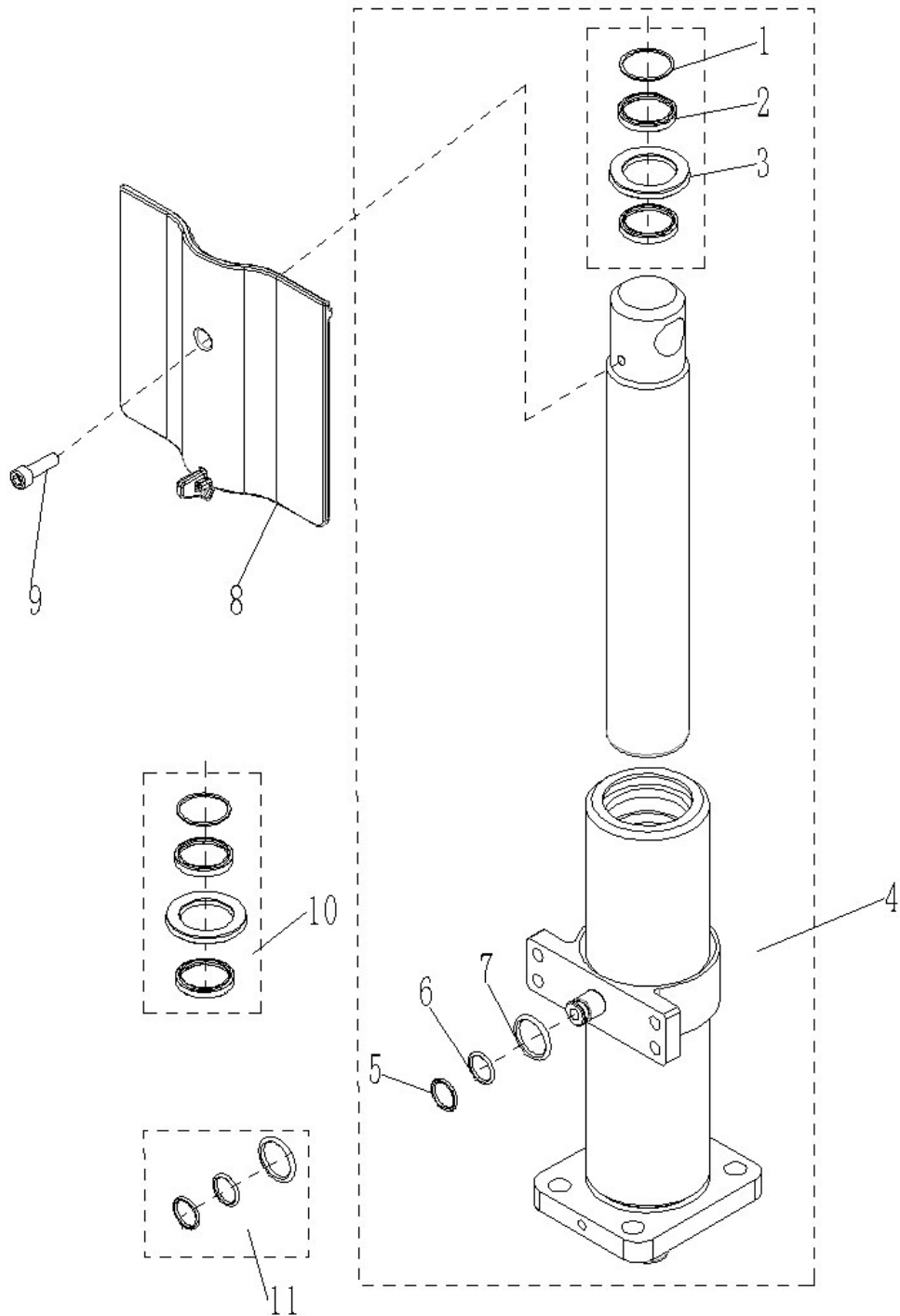
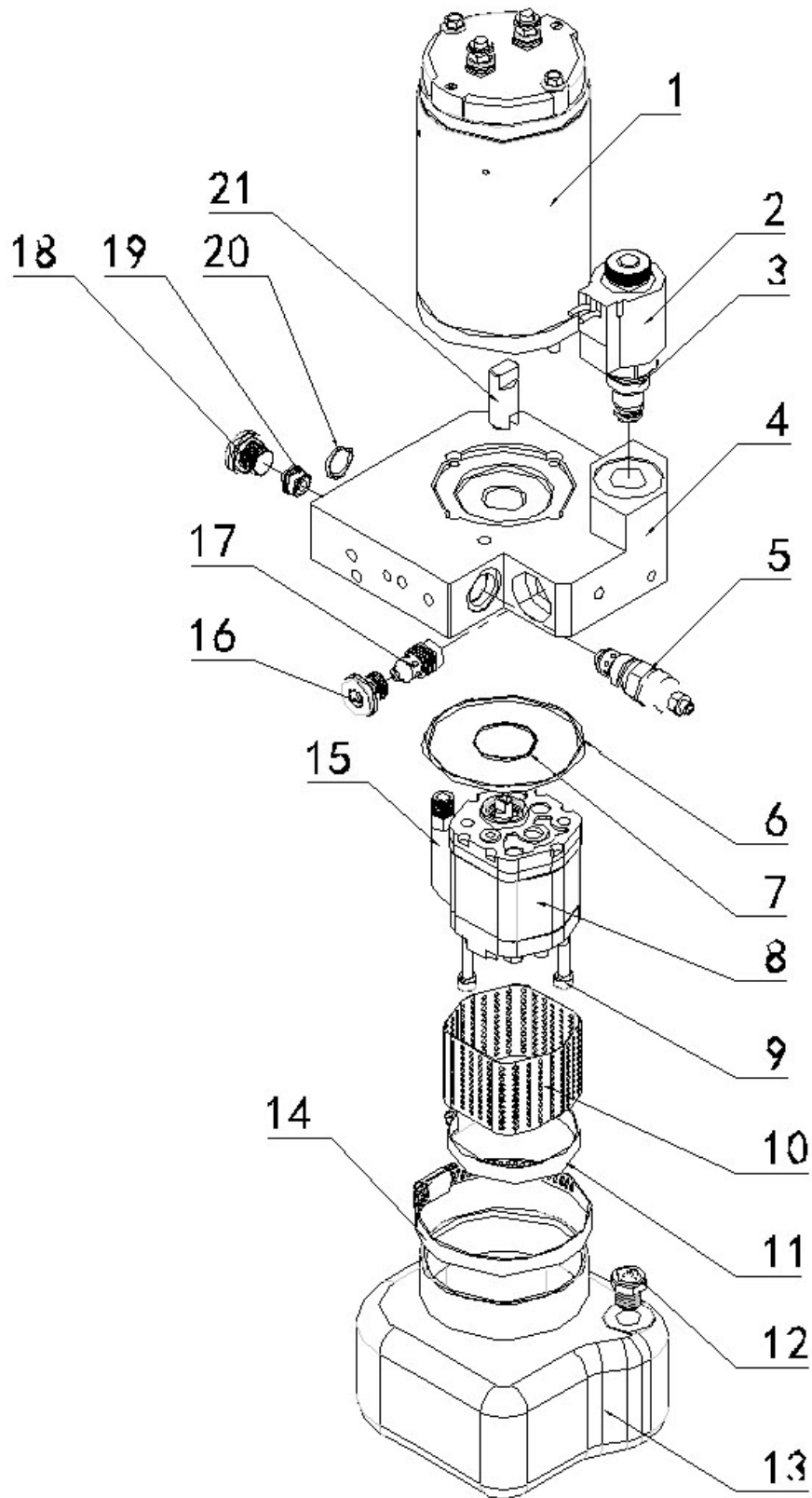

**Fig. 6 Cylinder**

No.	Art No.	Description	Qty.	Note
1	910800400003	Dust ring FC35x43x5	1	
2	910800500009	Support ring 35x40x10	2	

3	910800300013	Seal ring Y35x45x6	1	
4	508524010000	Cylinder components	1	
5	910800800003	Circlip 12.7x9.8x1.25	1	
6	910800100001	O ring 9.5x1.8	1	
7	910800100098	O ring 13.5x1.8	1	
8	508524020011	Cylinder cover	1	
9	910200200033	Screw GB70.1-M6x12-8.8	1	
10	508598510005	Sealing components	1	
11	508598510004	Sealing components	1	

Fig. 7 Power unit



**Fig. 7 Power Unit**

No.	Art No.	Description	Qty.	Note
1	508598510007	DC Motor	1	MD48080AN
2	508598520001	48VDC coil	1	YC048DC tandem
3	505698520054	Valve core	1	SCV
4	508598520002	CMB3 valve block	1	CMB3-101-66E
5	504498510015	Over flow valve	1	RV-06
6	508598520003	O ring	1	67.95x2.62
7	910800100063	O ring 21.2x1.8	1	21.2x1.8
8	508598510008	CBU gear pump	1	CBU-F1038
9	508598520004	Screw	2	M5x60
10	508598520005	Filter	1	59-30
11	508598520006	Clamp	1	KG02
12	508598510009	Filter	1	Z3/8
13	508598510010	Plastic oil tank	1	0.4L-TP072A080-V
14	508598520007	Clamp	1	KG04
15	508598520008	Oil return tube	1	RU10-060
16	505698520043	Plug	1	SP-09
17	505698520041	Pressure compensation valve	1	RPCV-02-04
18	505698520037	Plug	1	SP-02
19	505698520038	Built-in check valve	1	CV-03
20	910800100098	O ring 13.5x1.8	1	13.5x1.8
21	508598520009	Coupler	1	DCP-312

**Fig. 8 Hydraulic components**

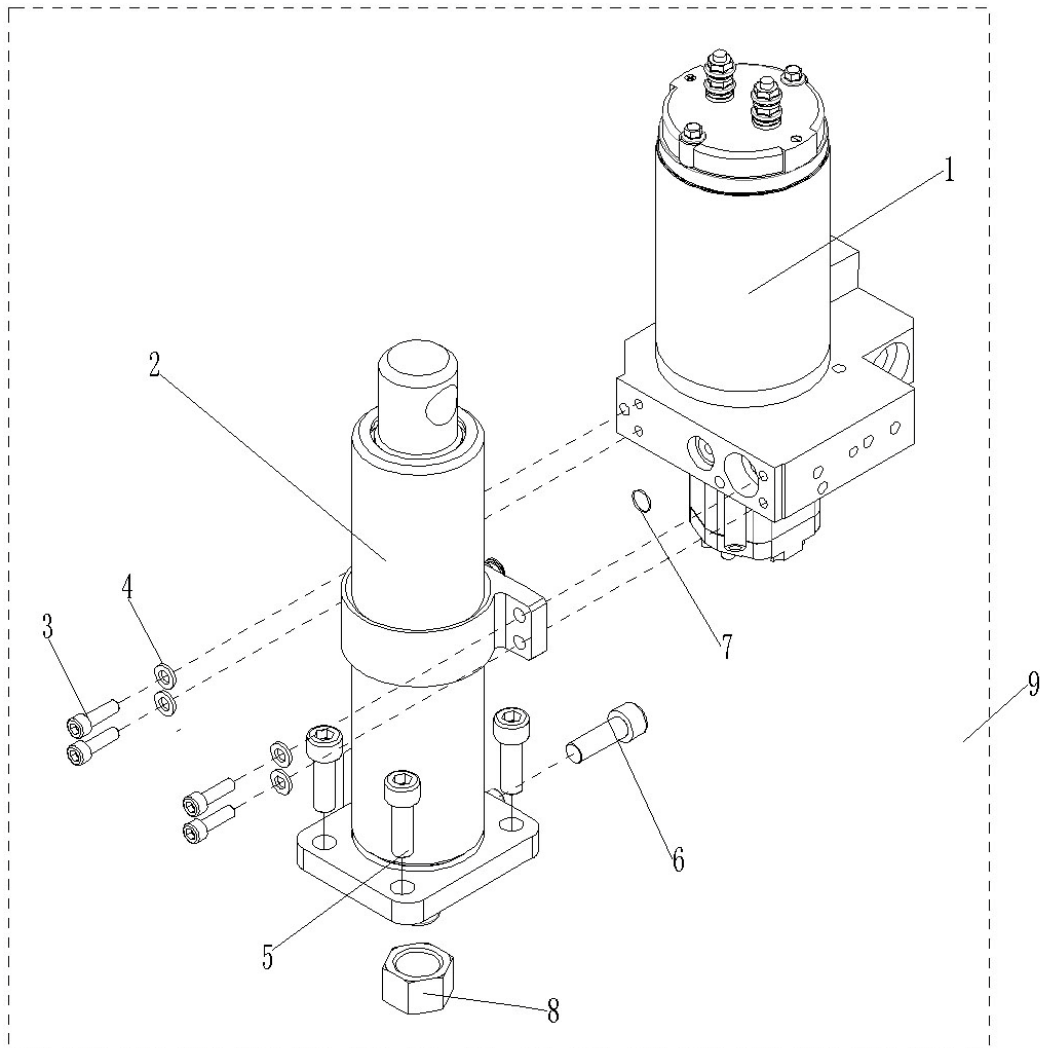
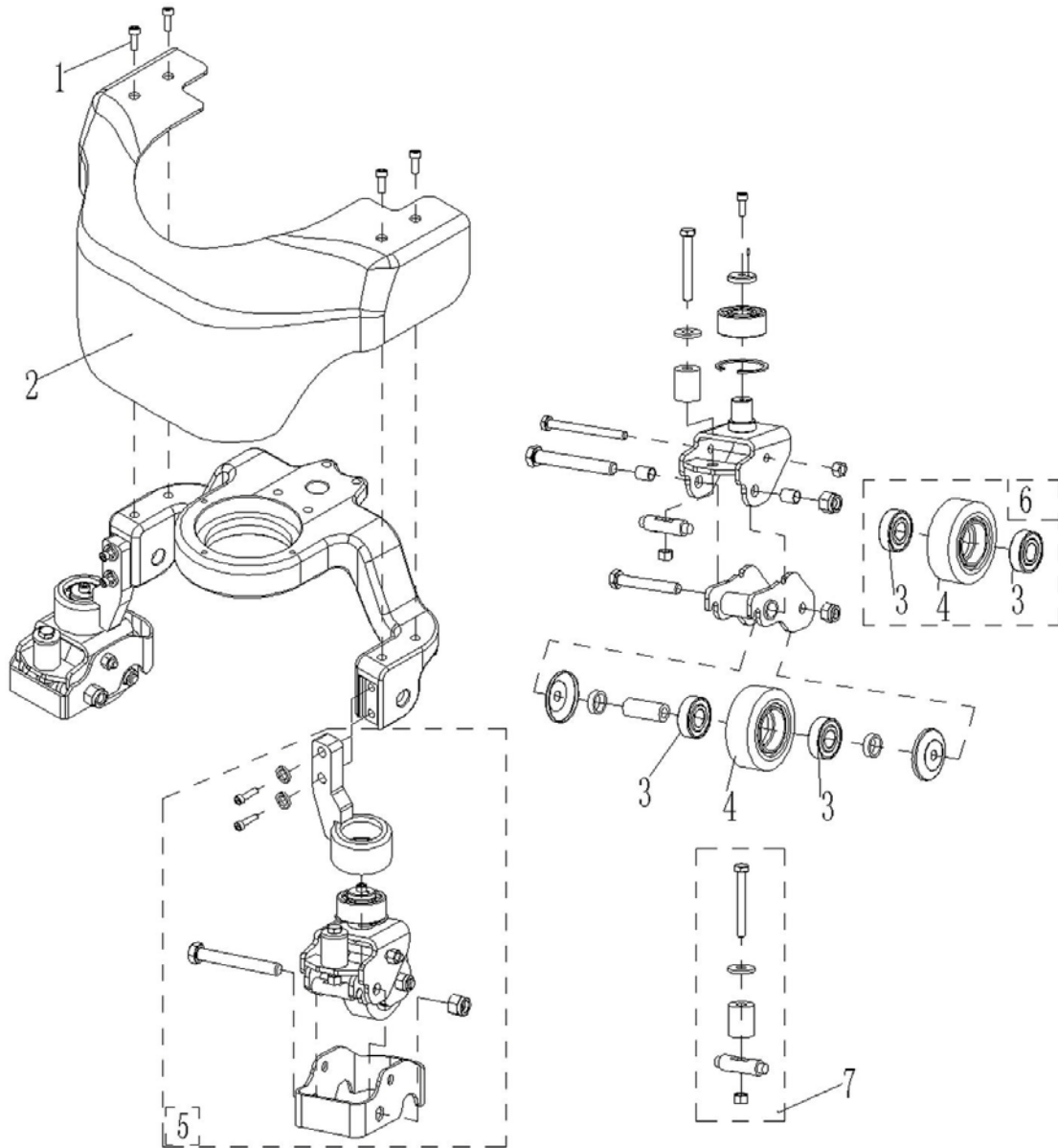

**Fig. 8 Hydraulic Components**

No.	Art No.	Description	Qty.	Note
1	950900100057	Hydraulic power unit 48V0.8KW0.38cc	1	
2	508524010000	Cylinder assembly	1	
3	910200200036	Screw GB70.1-M6x20-8.8	4	
4	910400100005	Flat washer GB97.1-6-200HV	7	
5	910200200077	Screw GB70.1-M10x30-8.8	4	
6	910200200045	Screw GB70.1-M6x6-8.8	1	
7	910800100098	O ring	1	13.5x1.8
8	910300400008	Nut GB6173-M20x1.5-05	1	
9	508524001000	Hydraulic components	1	



**Fig. 9 Steering wheel components (with side rollers)**



**Fig. 9 Steering Wheel Components (with side rollers)**

No.	Art No.	Description	Qty.	Note
1	941100100005	Screw M10x15-8.8	4	
2	508016520000	Apron (side roller)	1	
3	910700200018	Bearing GB276-6203-2RS	2	
4	940300300017	Roller $\Phi$ 80x30(Steel core PU)	1	
5	508016510000	Side roller components $\Phi$ 80x30(PU)	1	
6	502398510015	Roller components	1	
7	502398510016	Spring components	1	

**Fig. 10 Tiller head**

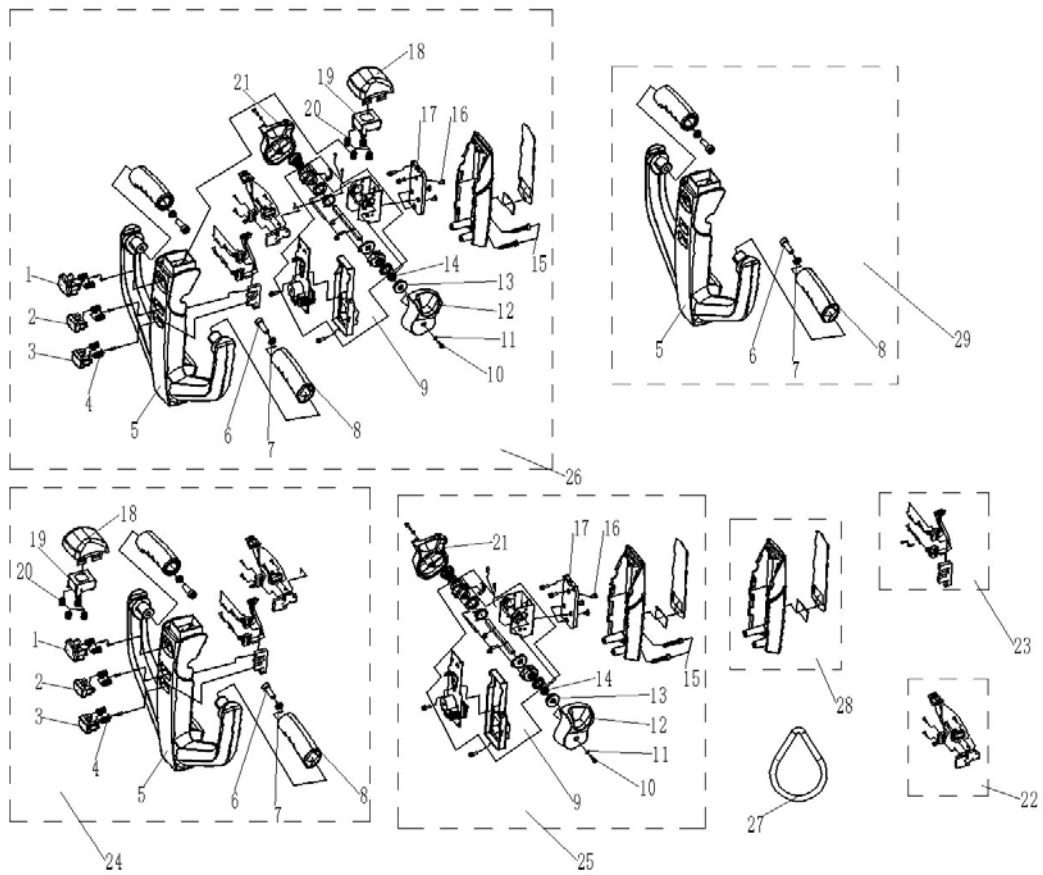
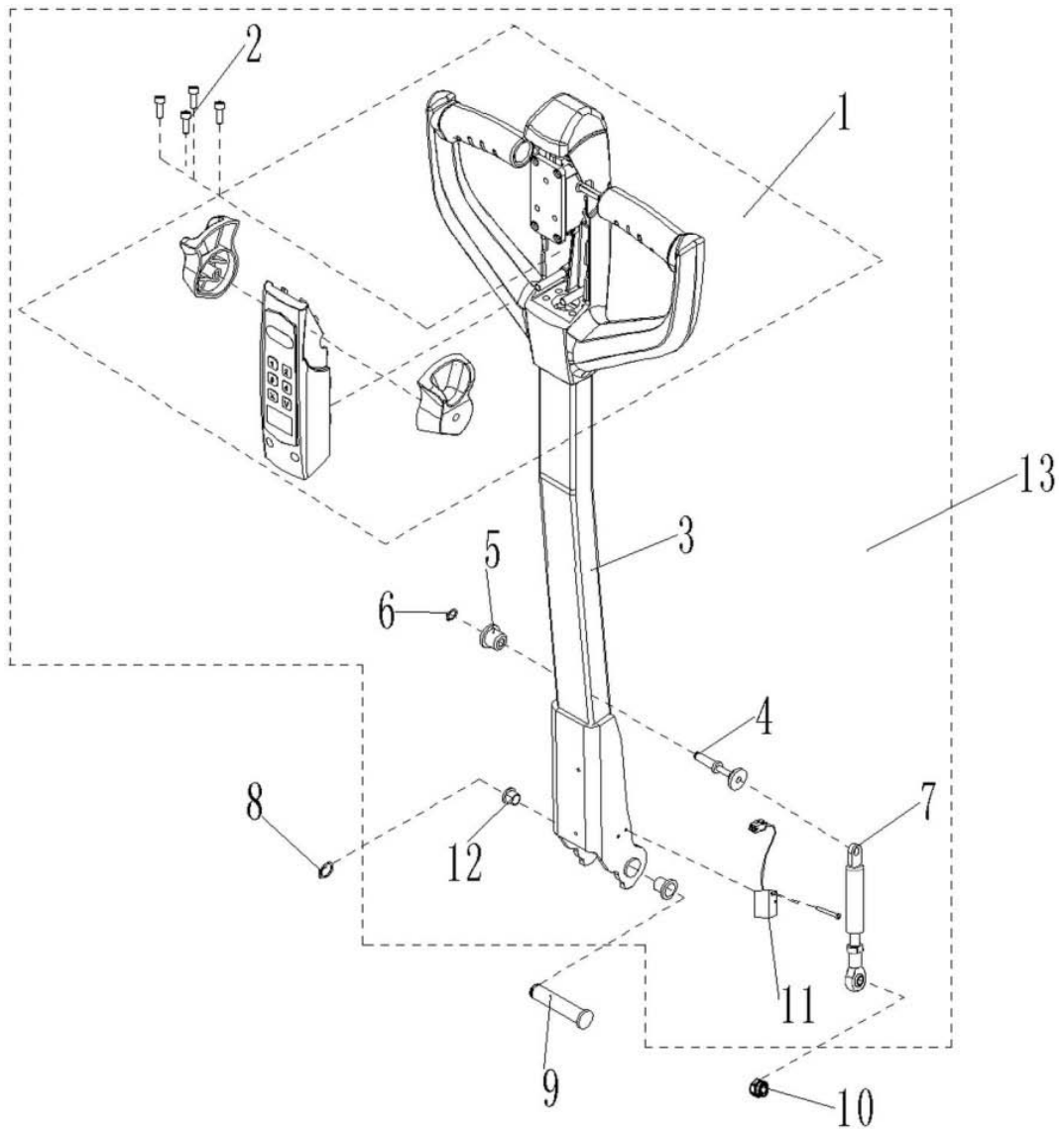

**Fig. 10 Tiller Head**

No.	Art No.	Description	Qty.	Note
1	502398520009	Horn	1	
2	502398520010	Lifting button	1	

3	502398520011	Lowering button	1	
4	502311020022	Spring 0.6	6	Height 16
5	508098520012	Tiller upper cover	1	
6	910200200058	Bolt	2	M8*25
7	910400500006	Washer	2	Φ 8
8	508098520013	Grip	2	
9	508098510028	Accelerator assembly	1	Components
10	910200200003	Bolt	2	M3*12
11	910400500002	Washer	2	Φ 3
12	508098520014	Left driving knob	1	
13	508098520015	Axle external bushing	2	
14	508098520016	Axle internal bushing	2	
15	910200200159	Screw GB70.1-M5x50-8.8	2	M5*50
16	910202000001	Screw	3	M4*6
17	508098520017	Accelerator fixing plate	1	
18	508098520018	Belly button base	1	
19	508098520019	Belly internal base	1	
20	502311020018	Spring 0.8	4	Height 11
21	508098520020	Right driving knob	1	
22	508098510029	Horn micro switch components	1	
23	508098510030	Lifting and lowering micro switch components	1	
24	508098510031	Tiller upper cover components	1	
25	508598510011	Tiller bottom cover components	1	
26	922100100016	Tiller N200(26C-1)	1	
	922100100020	Tiller N200(26C-3)	1	With card
27	508598520000	Tiller ID card	1	
28	508598510015	Display panel assembly	1	
29	508098510046	Handle cover fitting	1	

**Fig. 11 Tiller arm components**

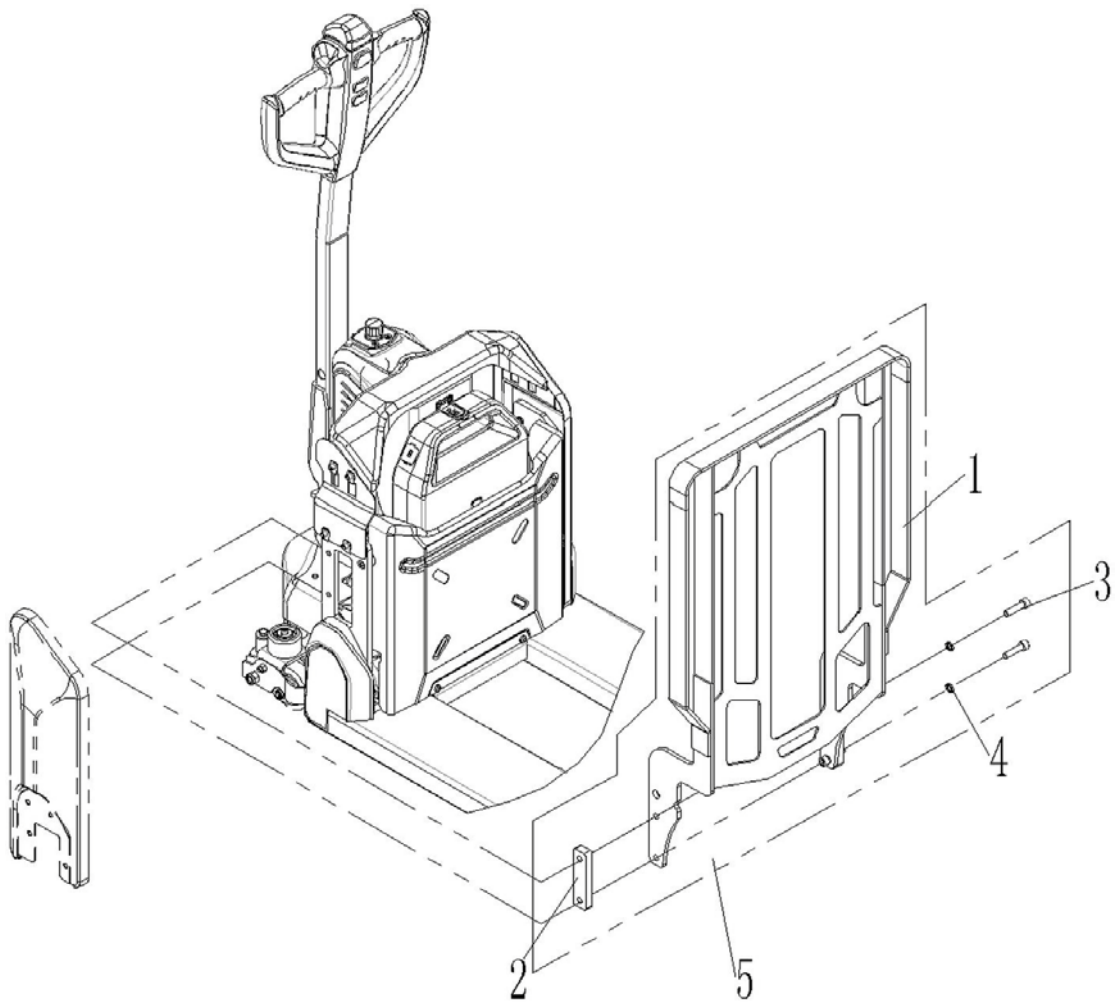

**Fig. 11 Tiller Arm Components**

No.	Art No.	Description	Qty.	Note
1	922100100016	Tiller N200(26C-1)	1	
	922100100020	Tiller N200(26C-3)	1	With card
2	910200200040	Screw GB70.1-M6x35-8.8	4	
3	508011010000	Tiller arm welding	1	
4	508011010002	Fixing axle welding	1	
5	508011020005	Fixing base	1	
6	910401300001	Circlip GB894.1-8	1	
7	508011010001	Air spring (D245)	1	

8	910401300006	Circlip GB894.1-15	1	
9	508011020004	Short axle $\Phi$ 15x70	1	
10	910200200057	Screw GB70.1-M8x20-8.8	1	
11	505633510002	Proximity switch NBN5-F7-E2(800mm)	1	
12	940500200001	Bushing (With shoulder) $\Phi$ 15x $\Phi$ 17x9-SF-1	2	
13	508598510006	Tiller components	1	
	508598510013	Tiller components	1	With card

**Fig. 12 Load backrest components**



**Fig. 12 Load Backrest Components**

No.	Art No.	Description	Qty.	Note
1	508040510000	Load backrest welding (1070)	1	
	508040510001	Load backrest welding (1220)	1	
	508040510002	Load backrest welding (1525)	1	
2	508040520000	Plate	2	
3	910200200079	Screw GB70.1-M10x40-8.8	4	
4	910400500007	Spring washer GB93-10	4	
5	508040501000	Load backrest assembly (1070)	1	
	508040501001	Load backrest assembly (1220)	1	
	508040501002	Load backrest assembly (1525)	1	

**Fig. 13 Truck components**

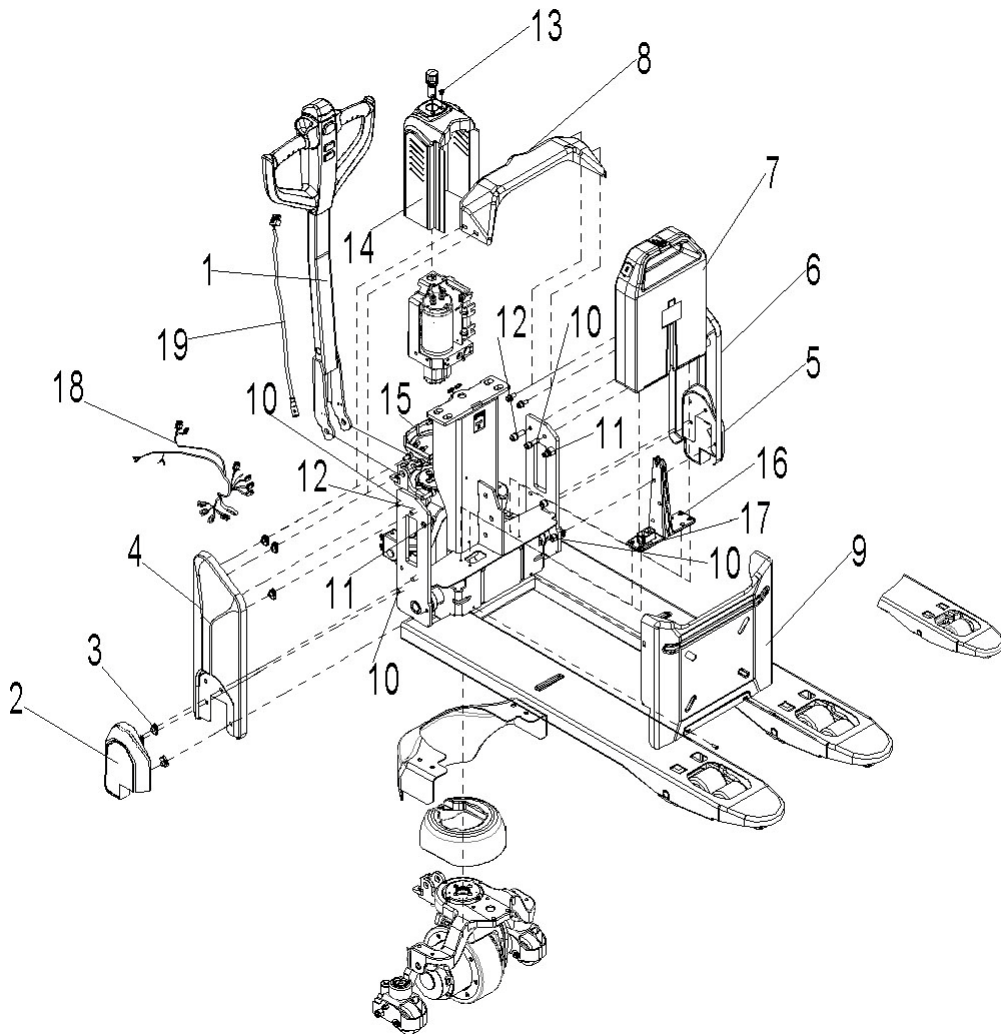

**Fig. 13 Truck Components**

No.	Art No.	Description	Qty.	Note
1	508598510006	Tiller components	1	
	508598510013	Tiller components	1	With card
2	508038510103	Small side cover (right) (540)	1	
	508038510105	Small side cover (right) (685)	1	
3	940400400002	Nut M8-t(2-4)	14	
4	508038510101	Side panel (Right )	1	
5	508038510102	Small side cover (left) (540)	1	
	508038510104	Small side cover (left) (685)	1	
6	508038510100	Side panel (Left )	1	

7	508537010000	Lithium battery 48V20Ah	1	20Ah
8	508038520100	Top cover	1	
9	508038520101	Front cover	1	
10	910200200058	Screw GB70.1-M8x25-8.8	10	
11	910200200055	Screw GB70.1-M8x16-8.8	6	
12	910400100006	Flat washer GB97.1-8-200HV	6	
13	910200400015	Screw GB70.3-M6x10-8.8	2	
14	508524020010	Motor cover	1	
15	508524020012	Motor cover base	1	
16	920600100045	Lithium battery holder	1	
17	910200500037	Screw GB818-M5x10-4.8	4	M5x10
18	508533010000	Main control wiring harness (CURTIS1226BL-4153+ZD)	1	
	508533010009	Main control wiring harness (CURTIS1226BL-4153+ZD+JS)	1	
19	508533010001	Tiller control wiring harness	1	



**Fig. 14 Power supply assembly**

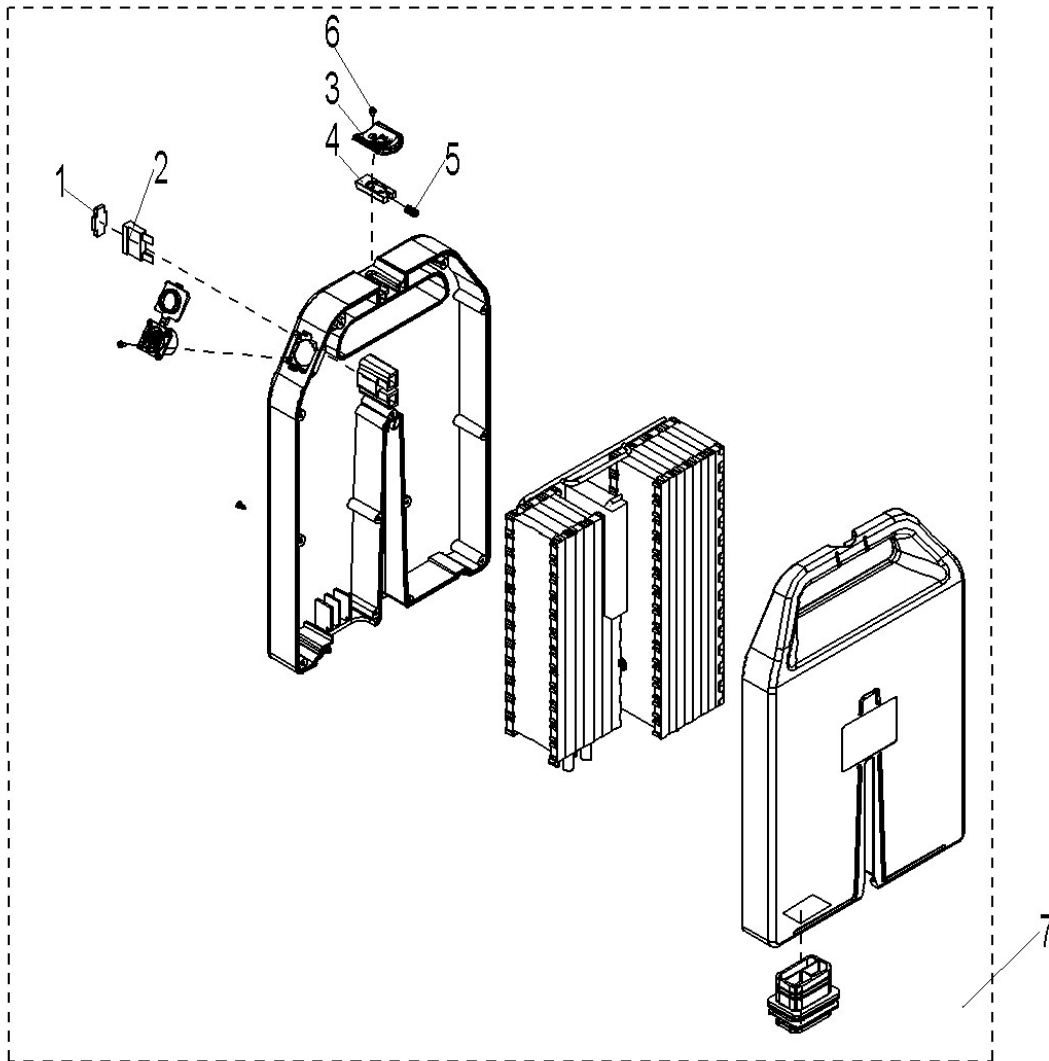

**Fig. 14 Power Supply Assembly**

No.	Art No.	Description	Qty.	Note
1	508098520021	Fuse protective cap	1	
2	920100200007	70A fuse	1	ATM70A DC80V
3	508098520022	Locker	1	
4	508098520023	Aluminium part	1	
5	508098520024	Spring	1	
6	910200500010	Screw	2	GB818-M3x8-4.8
7	508537010000	Lithium battery 48V20Ah	1	20Ah

**Fig. 15 Controller components**

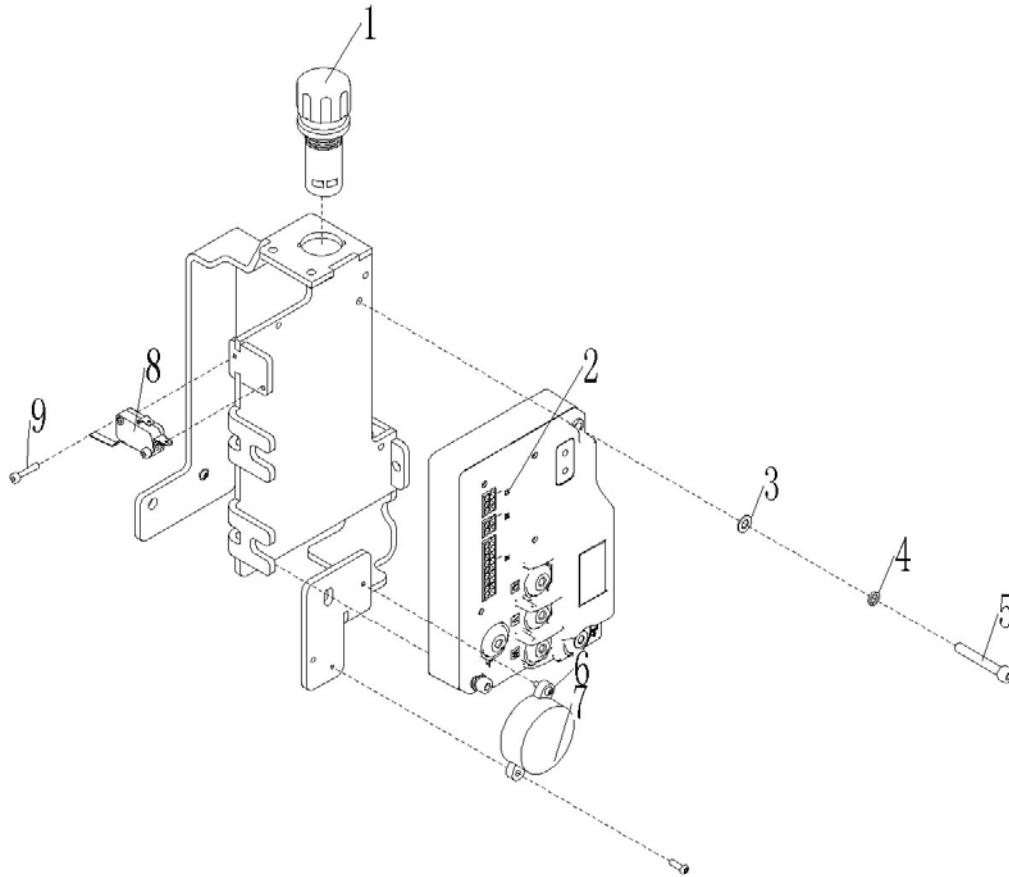

**Fig. 15 Controller Components**

No.	Art No.	Description	Qty.	Note
1	920200100015	Emergency button CE3T-10R-02	1	
2	921400100093	Controller 1226BL-4153	1	
3	910400100004	Flat washer GB97.1-5-200HV	2	Flat washer GB97.1-5-200HV-A-c1B
4	910400500004	Spring washer GB93-5	2	Spring washer GB93-5-c1B
5	910200200027	Screw GB70.1-M5x35-8.8	2	Screw GB70.1-M5x35-8.8-c1B
6	910200500010	Screw GB818-M3x8-4.8	2	Screw GB818-M3x8-4.8-Z-c1B
7	920500100004	Buzzer HYD-4216W-48V	1	
8	920200300015	Micro switch BH-KW9-10305A	1	
9	910200200004	Screw GB70.1-M3x16-8.8	2	Screw GB70.1-M3x16-8.8-c1B

**Fig. 16 Charger**

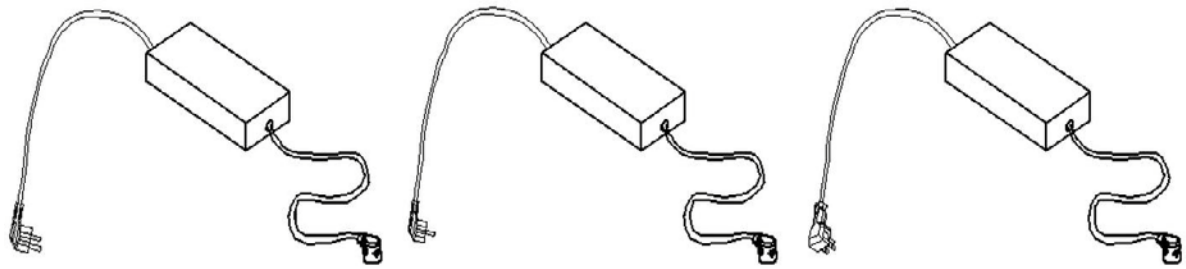

Chinese market

EU market

US market

**Fig. 16 Charger**

No.	Art No.	Description	Qty.	Note
1	921000200397	Lithium battery charger SS48V9A(Asia Chinese)	1	
2	921000200398	Lithium battery charger SS48V9A(US)	1	
3	921000200399	Lithium battery charger SS48V9A(EU)	1	

**Fig. 17 Wiring harness**

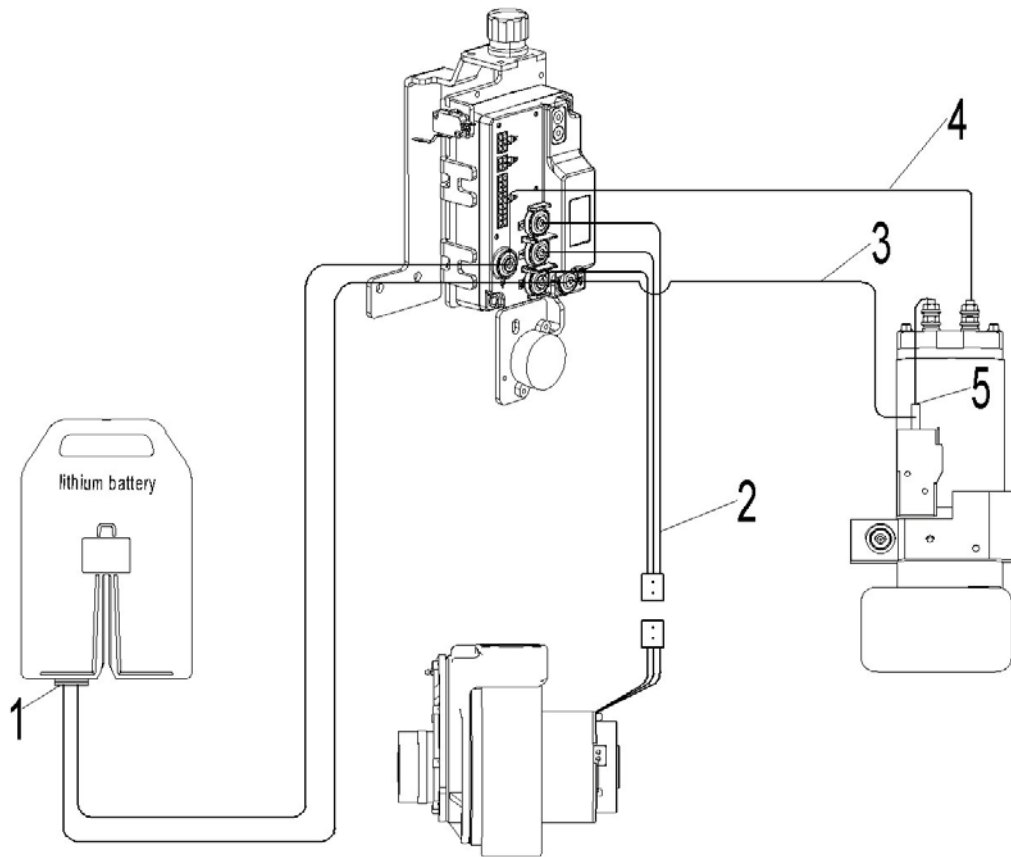

**Fig. 17 Wiring Harness**

No.	Art No.	Description	Qty.	Note
1	508533010003	Main plug wiring harness	1	
2	508533010007	Motor main wiring harness	1	
3	508533010004	Controller B+ wiring harness	1	
4	508533010005	Controller B- wiring harness	1	
5	508533010006	Pump motor B+ wiring harness	1	

**Fig. 18 Sticker (EU)**

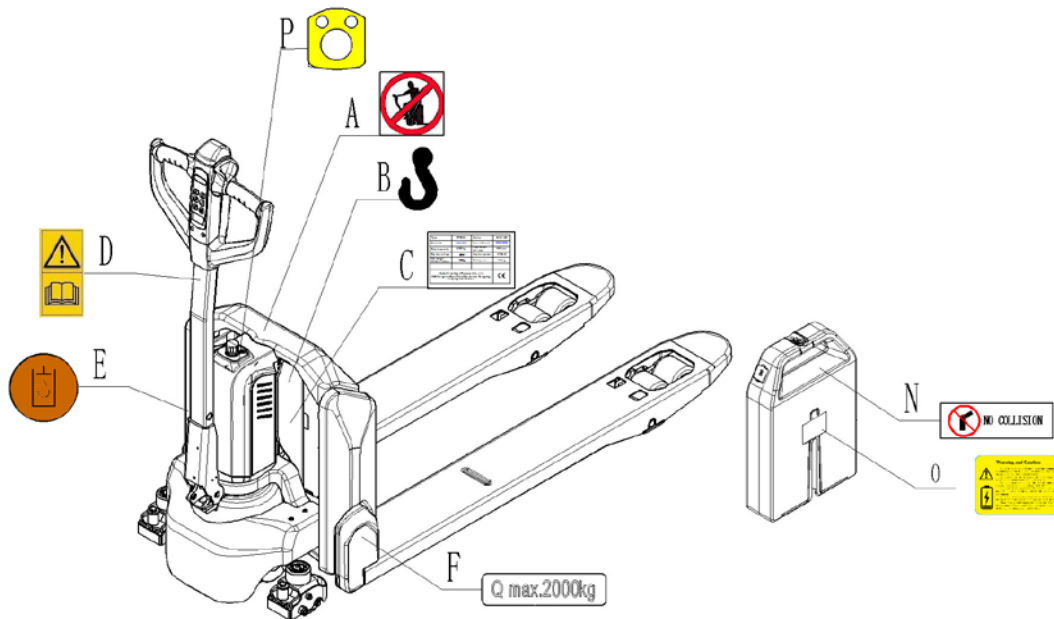

**Fig. 18 Sticker (EU)**

No.	Art No.	Description	Qty.	Note
A	941200100003	"No passengers" decal	1	
B	941200300001	Crane hook label	1	
C	508547520000	CE sticker (PTE20N540x1150)	1	
	508547520001	CE sticker (PTE20N685x1150)	1	
D	941200300002	Sticker to read and follow these instructions	1	
E	941200300003	Filling sticker	1	
F	941200200023	Capacity sticker	1	
N	508047020002	Warning sticker	1	
P	508547020000	Emergency button sticker	1	
O	508098520025	Warning sticker	1	

**Fig. 19 Sticker (US)**

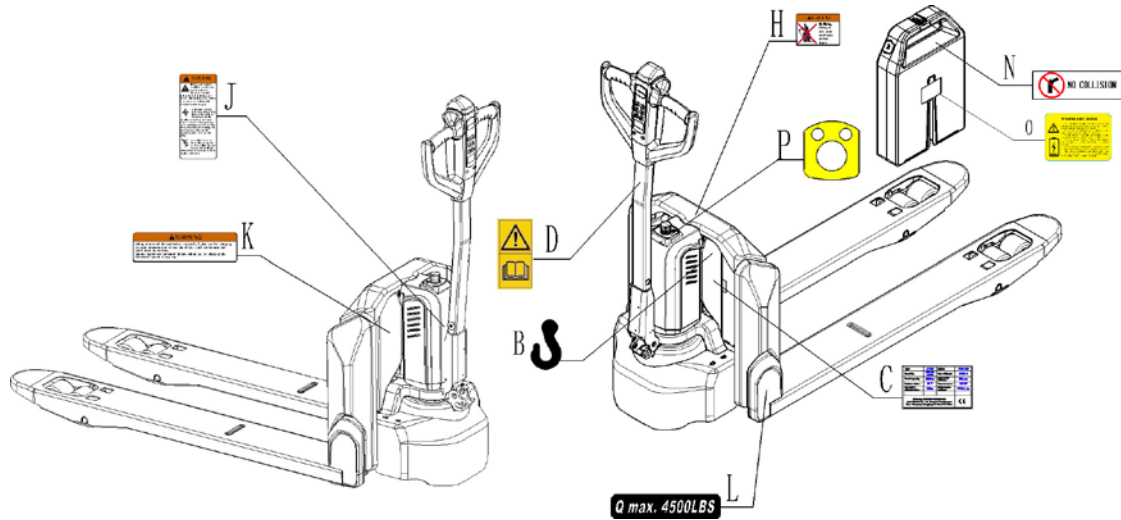

**Fig. 19 Sticker (US)**

No.	Art No.	Description	Qty.	Note
B	941200300001	Crane hook label	1	
C	508547520002	CE sticker (PTE20N21.3x45.3)	1	
	508547520003	CE sticker (PTE20N27x45.3)	1	
D	941200300002	Sticker to read and follow these instructions	1	
E	941200300003	Filling sticker	1	
H	941200100011	Warning sticker	1	
J	941200100009	Warning sticker	1	
K	941200100010	Warning sticker	1	
L	508547020000	Capacity sticker (4500LBS)	1	
N	508047020002	Warning sticker	1	
P	508547020000	Emergency button sticker	1	
O	508098520025	Warning sticker	1	

### Easy worn parts list

No.	Art No.	Description	Qty.	Fig./Position	Note
1	940500100033	Bushing $\Phi 25 \times \Phi 29 \times 12$ -SF-1	4	Fig. 1/4	
2	940500100006	Bushing $\Phi 16 \times \Phi 18 \times 15$ -SF-1	8	Fig. 1/9	
3	508098510037	Push rod components	2	Fig. 1/21	800
	508098510005	Push rod components			915
	508098510040	Push rod components			1000
	508098510000	Push rod components			1150
	508098510041	Push rod components			1220
4	508598510000	Rock arm components	1	Fig. 1/22	
5	508098510038	Push rod kits	2	Fig. 1/23	800
	508098510006	Push rod kits			915
	508098510043	Push rod kits			1000
	508098510002	Push rod kits			1150
	508098510044	Push rod kits			1220
6	508098510004	Push rod fork components	2	Fig. 1/24	
7	940500100032	Bushing $\Phi 25 \times \Phi 29 \times 25$ -SF-1	4	Fig. 2/4	
8	940500100006	Bushing $\Phi 16 \times \Phi 18 \times 15$ -SF-1	8	Fig. 2/9	
9	508598510001	Rock arm components	1	Fig. 2/22	685
10	508098510037	Push rod components	2	Fig. 2/21	800
	508098510005	Push rod components			915
	508098510040	Push rod components			1000
	508098510000	Push rod components			1150
	508098510041	Push rod components			1220
11	508098510038	Push rod kits	2	Fig. 2/23	800
	508098510006	Push rod kits			915
	508098510043	Push rod kits			1000
	508098510002	Push rod kits			1150
	508098510044	Push rod kits			1220

12	508098510004	Push rod fork components	2	Fig. 2/24	
13	910700200019	Bearing GB276-6204-2RS	8/4(Tandem/ single)	Fig. 3/4	
14	940300300005	Roller $\Phi$ 80x70(Steel core PU)	4(Tandem)	Fig. 3/5	
15	940300300023	Roller $\Phi$ 80x93(Steel core PU)	2(Single)	Fig. 3/10	
16	940500200003	Bushing (With shoulder) $\Phi$ 18x $\Phi$ 20x12-SF-1	4 (Tandem)	Fig. 3/11	
17	940500100012	Bushing $\Phi$ 20x $\Phi$ 22x12-SF-1	4	Fig. 3/12	
18	502398510014	Wheel set kits (single)	2	Fig. 3/13	
19	502398510003	Entry roller kits	2	Fig. 3/14	
20	502398510020	Roller kits (Tandem)	2	Fig. 3/15	
21	502398510017	Roller kits (single)	2	Fig. 3/16	
22	502398510019	Frame of roller components (75mm Tandem)	2	Fig. 3/17	Low profile
23	502398510002	Wheel set kits (Tandem)	2	Fig. 3/18	
24	910700200058	Bearing GB276-6013-2RS	1	Fig. 4/4	
25	910700600044	Bearing GB297-32913	1	Fig. 4/6	
26	910800800003	Circlip 12.7x9.8x1.25	1	Fig. 6/5	
27	910800100001	O ring	1	Fig. 6/6	9.5x1. .8
28	910800100098	O ring	1	Fig. 6/7	13.5x1 .8
29	508598510005	Sealing components	1	Fig. 6/10	
30	508598510004	Sealing components	1	Fig. 6/11	
31	508598520003	O ring	1	Fig. 7/6	67.95x 2.62
32	910800100063	O ring 21.2x1.8	1	Fig. 7/7	21.2x1 .8
33	910800100098	O ring 13.5x1.8	1	Fig. 7/20	13.5x1 .8
34	910800100098	O ring	1	Fig. 8/7	13.5x1 .8
35	910700200018	Bearing GB276-6203-2RS	2	Fig. 9/3	
36	940300300017	Wheel $\Phi$ 80x30(steel core PU)	1	Fig. 9/4	



37	508016510000	Side roller components $\Phi$ 80x30(PU)	1	Fig. 9/5	
38	502398510015	Roller components	1	Fig. 9/6	
39	502398510016	Spring components	1	Fig. 9/7	
40	940500200001	Bushing (With shoulder) $\Phi$ 15x $\Phi$ 17x9-SF-1	2	Fig. 11/12	
41	920100200007	70A fuse	1	Fig. 14/2	ATM7 0A DC80 V