

# INTRODUCTION

The new model of electric pallet truck developed by Noblelift is the innovative product with cutting-edge design based on decades of our experience, it combines the advantages of manual and electric pallet trucks being the perfect electrical product for light and medium duty material transportation in most effortless and economic way.

With its new and fresh outer appearance containing sharp lines, we named it "EDGE".

Now we have both 1500kg/3300lbs and 2000kg/4500lbs as the Edge Series.

Smart design

Robustness

Safety

Ergonomics

High performance

Maintenance friendly



Official website



Our Wechat

## Noblelift Headquarters

Add:#528 Changzhou Road, Taihu Sub-district, Changxing, 313100, China  
TEL:+86 572 6210311/6120989  
FAX:+86 572 6210777  
WEB:www.noblelift.com  
Email: info@noblelift.com

## Noblelift North America Corp.

Add:2461 S Wolf Road, Des Plaines, IL 60018  
Tel:847-595-7100  
Fax:847-595-7200  
Email:sales@nobleliftna.com  
Http: www.nobleliftna.com

## Noblelift Europe GmbH

Add:Borsigstrasse 9d-93092 Barbing Germany  
TEL:+49 9401 607930  
FAX:+49 9401 6079329  
WEB:www.noblelifteuropr.com  
Email: mail@noblelifteurope.com

## Noblelift Russia

ООО "Ноблелифт Рус"  
194292, Санкт-Петербург  
Домостроительная ул. 4А офис 301  
Бизнес-центр "Парнас"  
тел.: +7 (800) 700-28-97  
Email: sales@noblelift.com.ru

NEW ARRIVAL  
Noblelift Products

2000kg  
4500lbs  
Capacity

- ✓ Brushless DC drive motor
- ✓ 48V Curtis control System
- ✓ Great Gradeability Performance
- ✓ Low Consumption of Energy



NOBLELIFT  
Material Handling

EDGE  
EDGE

Powered Pallet Truck



NOBLELIFT INTELLIGENT EQUIPMENT CO., LTD

www.noblelift.com

## Ergonomic & Smart Tiller Design

The tiller of the truck with ergonomic design has comfortable soft grips for comfort daily operation. All buttons are big and can be easily reached by operators even in case of working in gloves.

**Integrated PIN code panel with LCD display** for smart control and operation.



## Robust & Smart Design of Chassis

Strong and compact structure of chassis helps to ensure long life-time of the truck, without sacrificing the truck's weight or putting under question the strength of frame.

The frame of truck is surrounded by stamped steel elements making the truck looking different and also ensuring the **protection** of components



**Strong** steel apron **protects** the operator's feet during work and secures the truck's components from collisions with objects.



**Standard** with suspension stability casters for great stability for applications of all kinds.

Forks of the truck with shape for easy entrance and exit from pallets. Full length double sided C-shape **reinforcements** of forks significantly increase strength and **rigidity** of frame.



Great gradeability performance with **7%** gradeability when it is fully loaded with **4500lbs(2000kg)**, **16%** when it not loaded. Standard with German INTORQ brake for safety.



## Smart Lithium Battery

Standard with Maintenance-free 48V/20Ah Lithium battery and 48V/9A intelligent charger for long operation time, fast charging and opportunity charging.

The integrated **BMS** (Battery Management System) controls all important parameters and performance of lithium battery.



Socket on battery case for easy battery charging without necessity to take the battery out. Fast and opportunity charging during brakes in operations increases working time.



Smart battery positioning and lock for great fixation and safety.



Light weight high quality Lithium battery for **easy replacement**.

## Maintenance Friendly

48V Brushless DC drive motor with intelligent Curtis control



**Convenient** and fast access to any component of the truck, no elements are located in areas difficult to reach. No Special tools are required.

There are no hoses or pipes used in the hydraulic lifting circuit which significantly improves **reliability** and reduces the amount of potential problems related to leakages through connectors or their seals.

CAN-bus



The truck is equipped with **Curtis** controller and **CAN-bus** technology makes the diagnostic and troubleshooting easier.

Amount of working hours shown at the tiller helps to follow the maintenance schedule.

## Various Options



Please write single or tandem rollers



Optional different fork sizes



Optional Backrest

**Different heights**  
1070mm/42in  
1220mm/48in  
1525mm/60in



The function of driving with tiller in the **vertical position** helps with work in confined areas, especially in elevators and lorries without sacrificing of safety.



**540mm Fork: 149kg**  
21in Fork: 328lbs  
**685mm Fork: 153kg**  
27in Fork: 337lbs

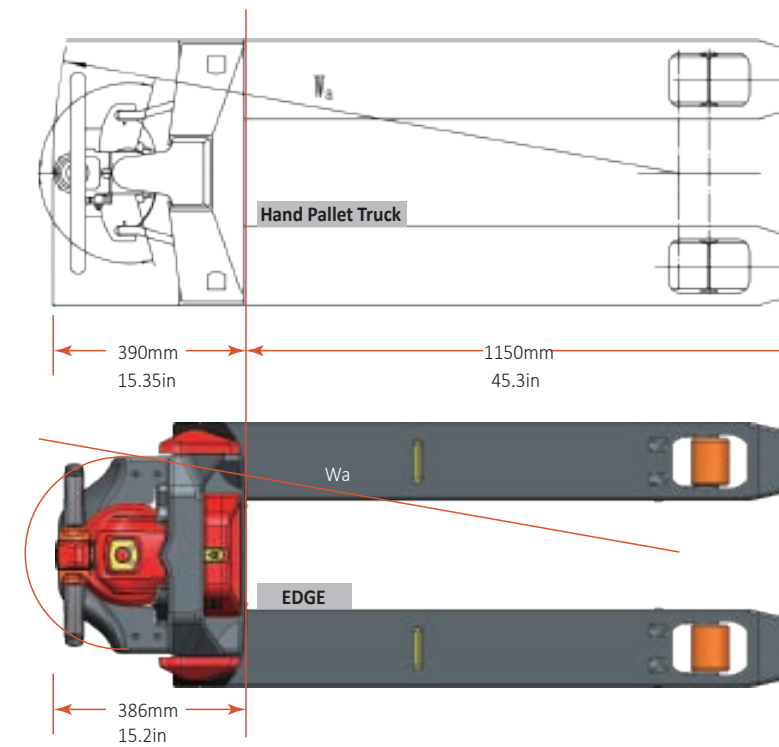

The short body length of truck (L2=386mm/15.2in) is even smaller that the one of regular HPTs. It provides the shortest **turning radius of 1280mm(50.4in)/1336mm(52.6in)** with lifted/lowered forks and makes the truck extremely compact and ideal for use in confined spaces of retail stores, elevators or business centers.